



R E S I D E N T I A L P L A S T I C S E A T S



# 1000CP Paramont™

Seats shall be No. 1000CP as manufactured by Bemis Manufacturing Co. Seats shall be heavy weight and injection molded of solid plastic. Seats shall be closed front with cover to fit round and elongated bowls. Seats are 3/4" wider on each side and feature exclusive Posturemold® design and large molded-in bumpers for easy cleaning. Seats shall contain our CP hinge, our strongest hinge on a covered seat, made of chrome-plated brass. Pintles will be stainless steel. This sturdy hinge design will prevent wobbling. Color to be white.

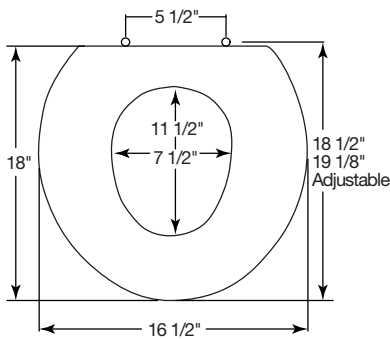

Ring thickness is 7/8"  
 Ring thickness including the bumper is 23/32"  
 Height of the seat with cover is 2"



CP HINGE MADE OF CHROME-PLATED BRASS

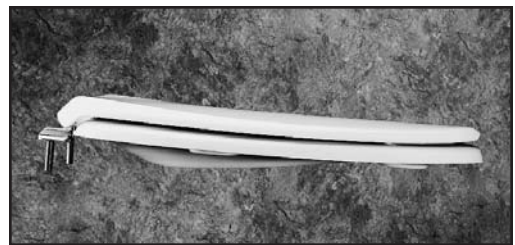

1000CP PROFILE



TWO-POSITION HINGE FITS EITHER ROUND OR ELONGATED BOWLS

\*\* ANSI Z124.5 section 5.1.2 Tests have shown that this product will support weights up to 500 pounds.\*\*  
 (Contact Bemis Mfg. Co., for test data)